

Z Series

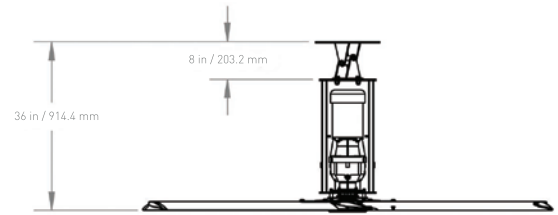

STANDARD FEATURES

- Clearcoat anodized airfoil blades
- Forward, reverse, variable speed
- Variable frequency drive- basic fire alarm integration
- Analog remote for one-to-one fan control
- Safety Components: Safety Cable, Universal Mount with Guy Wires, Blade Retainer Links



STEP 1: DIAMETERS

Item #	Diameter	Motor Horsepower	Qty
MZ08	8 ft / 2.44 m	1.0 HP	
MZ10	10 ft / 3.05 m	1.0 HP	
MZ12	12 ft / 3.66 m	1.0 HP	
MZ14	14 ft / 4.27 m	1.0 HP	
MZ16	16 ft / 4.88 m	1.0 HP	
MZ18	18 ft / 5.49 m	1.0 HP	
MZ20	20 ft / 6.07 m	1.5 HP	
MZ24	24 ft / 7.32 m	2.0 HP	

STEP 2: VOLTAGE

Item #	Voltage Options	Qty
1xx1-MA	100-120V Single Phase, 50/60 Hz*	
2xx1-MA	208-240V Single Phase, 50/60 Hz	
2xx3-MA	208-240V Three Phase, 50/60 Hz	
4xx3-MA	480V Three Phase, 50/60 Hz	
6xx3-MA	600V Three Phase, 50/60 Hz*	

xx=horsepower

STEP 3: MOUNTING

Item #	Mount Options	Qty
60-90006-00	Series Universal Mount: I-beam Hardware Kit	
60-40041-00	Glulam Hardware Kit (for Universal Mount)	

STEP 4: CONTROLS

Item #	Description	Qty
30-90301-00	Analog Remote Assembly	

*100-120V Single Phase and 600V Three Phase voltage options are not available for 20 and 24 ft diameter Z Series fans

Z Series

OPTIONAL: EXTENSIONS

Item #	Length (ft/in)	Length (m)	Qty
50-800in-02	0 ft 1 in - 0 ft 11 in	0.025 m - 0.28 m	
50-801in-02	1 ft - 1 ft 11 in	0.30 m - 0.58 m	
50-802in-02	2 ft - 2 ft 11 in	0.61 m - 0.89 m	
50-803in-02	3 ft - 3 ft 11 in	0.91 m - 1.19 m	
50-804in-02	4 ft - 4 ft 11 in	1.22 m - 1.50 m	
50-805in-02	5 ft - 5 ft 11 in	1.52 m - 1.80 m	
50-806in-02	6 ft - 6 ft 11 in	1.82 m - 2.11 m	
50-807in-02	7 ft - 7 ft 11 in	2.13 m - 2.41 m	
50-808in-02	8 ft - 8 ft 11 in	2.44 m - 2.72 m	
50-809in-02	9 ft - 9 ft 11 in	2.74 m - 3.02 m	

Most extensions are built to order. Please order the necessary extension length at the same time that you order the fans.

in = length in inches (i.e. 05 for 5 inches, 10 for 10 inches)

To order Drop Length greater than 10 ft please call MacroAir.

OPTIONAL: POWDER COATING

Item #	Diameter	Estimated Lead Time	Qty
60-10008-PC	8 ft / 2.44 m	15 business days	
60-10010-PC	10 ft / 3.05 m	15 business days	
60-10012-PC	12 ft / 3.66 m	15 business days	
60-10014-PC	14 ft / 4.27 m	15 business days	
60-10016-PC	16 ft / 4.88 m	15 business days	
60-10018-PC	18 ft / 5.49 m	15 business days	
60-10020-PC	20 ft / 6.07 m	15 business days	
60-10024-PC	24 ft / 7.32 m	15 business days	

Special Blades Finishes

60-102xx-00 (Flat Black)	All Diameters	15 business days	
Hub Cover	All Diameters	15 business days	

xx = ft, fan diameter (i.e. 08 for 8ft, 20 for 20 ft)

For powder coating colors, please refer to Appendix A.

Do you have a custom color in mind? Custom powder coating is available for all our blades, mounts and drop lengths.

ADDITIONAL OPTIONS

Item #	Description	Qty
-FD	Food-Grade / Stainless Steel - 1.0 HP*	
-EX	Explosion Proof Motor -1.0 HP*	

*Only Available for 8ft-18ft

Z Series



- Controls 1 fan
- Simple and intuitive control

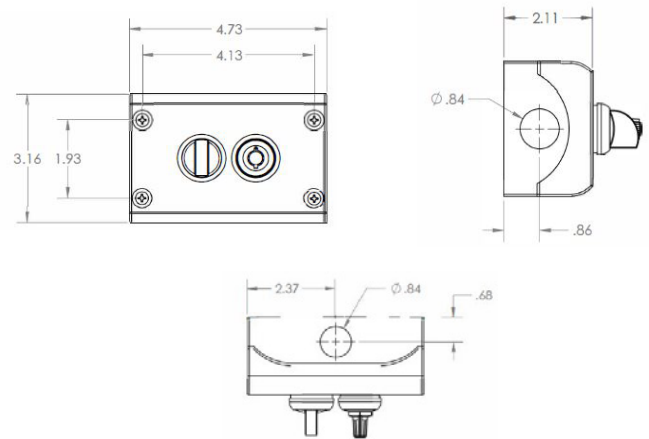

Features	Analog Remote
Item #	30-90301-00
# Fans Controlled	1 fan
Display	2.8 TFT
Rating	IP 65
Weight (incl. enclosure)	375 g
Communication Protocol	0-10V
Size (incl. enclosure)	91.2 x 135.5 x 42.0
Operating Temperature	16° to 158°F / -10° to +70°C
Storage Temperature	-22° to 176°F / -30° to +80°C

Z Series

BASIC SPECIFICATIONS

AIRFOIL DIAMETER	8ft	10ft	12ft	14ft	16ft	18ft	20ft	24ft
Airfoil Style	7.375" Extruded Anodized Aluminum Airfoil							
Number of Airfoils	6							
PERFORMANCE								
Max Speed	202 RPM	162 RPM	129 RPM	103 RPM	84 RPM	70 RPM	70 RPM	62 RPM
Recommended Spacing*	50 ft [15.2 m]	60 ft [18.3 m]	65 ft [19.8 m]	70 ft [21.3 m]	85 ft [25.9 m]	90 ft [27.4 m]	100 ft [30.5 m]	110 ft [33.5 m]
Max Affected Area	3,600 ft ² [336 m ²]	6,000 ft ² [557 m ²]	8,000 ft ² [743 m ²]	10,000 ft ² [929 m ²]	12,000 ft ² [1,115 m ²]	14,000 ft ² [1,301 m ²]	18,000 ft ² [1,673 m ²]	20,000 ft ² [1,858 m ²]
Sound Level dBA at Max Speed**	58	58	58	58	58	58	61	61
HANGING REQUIREMENTS								
Hanging Weight	171 lbs [77.56 Kg]	178 lbs [80.74 Kg]	189 lbs [85.73 Kg]	195 lbs [88.45 Kg]	202 lbs [91.63 Kg]	208 lbs [94.35 Kg]	217 lbs [98.43 Kg]	270 lbs [122.5 Kg]
Max Torque	18 lbf/ft [24 Nm]	24 lbf/ft [33 Nm]	31 lbf/ft [42 Nm]	43 lbf/ft [58 Nm]	40 lbf/ft [54 Nm]	58 lbf/ft [79 Nm]	88 lbf/ft [119 Nm]	126 lbf/ft [171 Nm]
Max Thrust in Reverse	4 lbs [1.8 kg]	6 lbs [2.7 kg]	9 lbs [4.1 kg]	14 lbs [6.4 kg]	15 lbs [6.8 kg]	21 lbs [9.5 kg]	31 lbs [14.1 kg]	44 lbs [20 kg]
MOTOR AND DRIVE TRAIN								
Motor Type	AC induction Motor with a sealed 2-stage helical gear box							
Equivalent Horsepower Rating	1.0 HP (8-18ft) / 1.5 HP (20ft) / 2.0 HP (24ft)							
Operating Temp Range	16°F [-10C°] - 104 F° [40C°]							
MAX AMP DRAW								
100-120V Single Phase***	16.6A	16.6A	16.6A	16.6A	16.6A	16.6A	N/A	N/A
208-240V Single Phase	20.2A	20.2A	20.2A	20.2A	20.2A	20.2A	20.2A	20.2A
208-240V Three Phase	10.8A	10.8A	10.8A	10.8A	10.8A	10.8A	10.8A	10.8A
480V Three Phase	4.3A	4.3A	4.3A	4.3A	4.3A	4.3A	4.3A	4.3A
600V Three Phase***	2A	2A	2A	2A	2A	2A	N/A	N/A
POWER AND CONTROLS								
Power Source	Single Phase 100-120 VAC / Single Phase 208-240 VAC / Three Phase 208-240 VAC / Three Phase 480 VAC / Three Phase 600 VAC 50/60 Hz							
Control Options	Analog Remote							
INSTALLATION								
Mounting Hardware	Universal Mount							
Extension	Optional extensions are available in 1ft increments; all drop lengths require guy wires							
RATINGS AND COMPLIANCE								
Fire and Sprinkler	NFPA Compliant							
Wash Down Duty Rating****	IP55							
Certifications	UL 507							

*For spacing between fan units based on the dimensions of a specific space please refer to <https://macroairfans.com/airviz>.

**Sound testing taken with the sensor 5 ft above the ground and 20 ft from the center of the fan at 20 ft high.

***100-120V Single Phase and 600V Three Phase voltage options are not available for 20 and 24 ft diameter Z Series fans

****Applicable to the fan unit only, does not include controller and control panel.

Fan Placement & Clearance

